



TIGER

372 CNC LR 4.0

TIGER 372 CNC LR 4.0, automatic electromechanical vertical sawing machine with HSS blade which can operate also in semi-automatic mode, to cut steels from 45° right to 60° left.

OPTIONAL VERSION: TIGER 372 CNC LR 4.0 RB, with automatic rotating table 3 positions: 45°left, 0° and 45°right.

- CNC machine with controlled double axis multimicroprocessor to obtain, on the same bar or on the material located on the loading magazine CB6001 (OPTIONAL), up to 300 cutting programs each of different lengths and quantities.
- CB 6001 for high production for round square and rectangular bars up to the maximum cutting dimensions indicated on the brochure. The CB6001 must be ordered together with the machine.

A FEW FEATURES:

- Panel with low tension controls: polyester membrane keypad with tactile thermo-shaped buttons which give out an acoustic signal when pressed.
- 8" touch screen display operator interface and push buttons for all functions of the sawing machine. It is simple and intuitive with a self-learning feature it guarantees a reliable use and it controls all cutting parameters in real time.



OPTIONALS FROM PAG 23 - N° 01 - 02 - 05 - 07 - 08 - 13 - 15 - 20 - 29 - 32 - 33 - 34 - 38 - 39 - 47



mm	kW	rpm	mm	0°	∅	○	□	▭	●	■	▬	kg
				45°	370	120	110	180x100	120	110	180x100	
HSS 372x32x3	5,5	15÷150	190	45°	370	115	100	120x100	70	70	70x70	1060
				60°	370	115	90	90x90	50	50	50x50	
				45°	370	115	100	120x100	70	70	70x70	

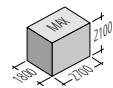
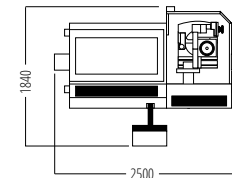



- The headstroke, according to the dimensions of the material which has to be cut, is set directly from the control panel.
- Transmission system at 3 stages so as to guarantee high sturdiness, precision and to obtain high removal capacities.
- Model with complete covering so as to reach 3 fundamental aims:
 - + operator's safety (during working cycles, access to cutting area is hindered by a timed opening system).
 - + Sound-proofness.
 - + Possibility to work with high quantity of cutting liquid (120 liters/min) to cool blade, to wash the working area continuously and to convey chips guaranteeing in this way longer blade life.
- Sawing head movement on double linear guides with preloaded slides with recirculating ballscrews.
- Head down stroke by means of electromechanical

- cylinder to obtain the maximum cutting rigidity and the automatic comparison of the data set/obtained and to correct cutting parameters in real time.
- Blade rotation with one speed motor with electronic speed variator so as to cut from 15 up to 150 rpm to obtain the best cutting efficiency.
- Wire chip brush for band cleaning.
- Rotation pin with preloaded thrust bearing to grant rotation precision and stability.
- Bar feeder has a length of 1000 mm and consists in a system given by screw/nut with recirculating ballscrews with stepper motor and vice with sideways movement so as to feed in also deformed bars.
- Pneumatic locking vice with adjustable steel gib.
- Pneumatic vertical vice.
- Special vice to reduce restpiece.
- Steel base with drawer to collect chips which can be replaced with a motorized chip evacuator (see

- optionals).
- Circular blade Ø 350 mm.
- Service keys and instructions manual for maintenance and spare parts list.

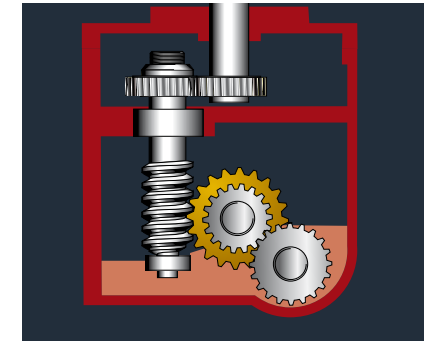

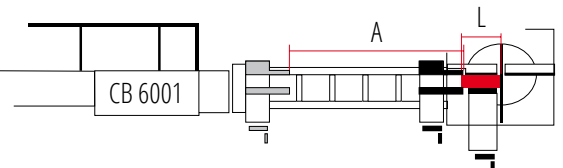
	A	L
	corsa alimentatore MAX mm	sfrido MAX mm
TIGER 372 CNC LR 4.0	1000	170
TIGER 372 CNC LR 4.0 + CB 6001	1000	180
TIGER 372 CNC LR 4.0 (RB + 45°- 0°- 45°)	900	270
TIGER 372 CNC LR 4.0 (RB + 45°- 0°- 45°) + CB 6001	900	280

